

Forced Convection Reflow Soldering System SMT Quattro Peak® L Plus (N₂)

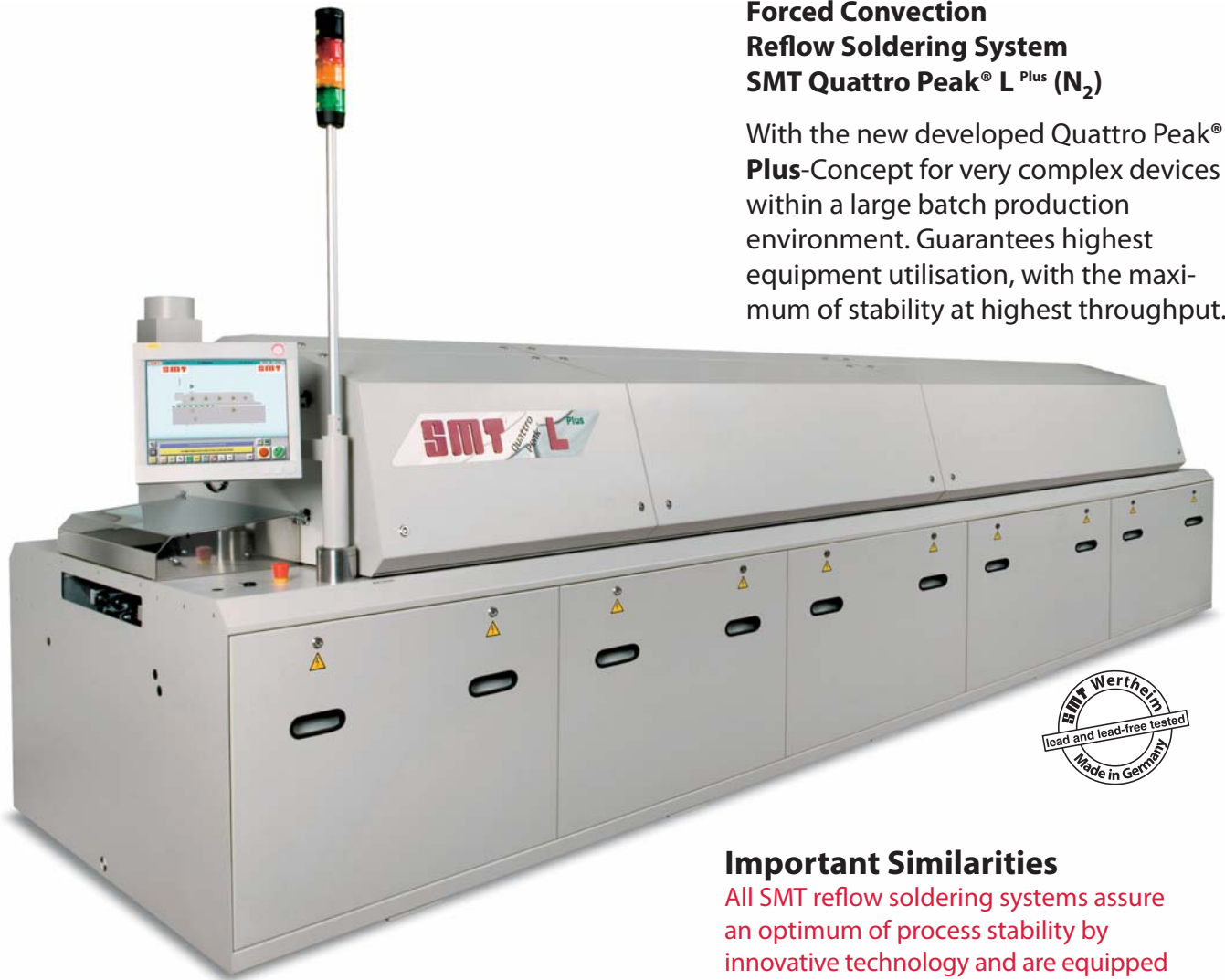

The Top-Performer - Plus
**Forced Convection
Reflow Soldering System
SMT Quattro Peak® L Plus (N₂)**

With the new developed Quattro Peak® Plus-Concept for very complex devices within a large batch production environment. Guarantees highest equipment utilisation, with the maximum of stability at highest throughput.



Important Similarities

All SMT reflow soldering systems assure an optimum of process stability by innovative technology and are equipped with the following advantages:

- Special power nozzle system for optimal heat transfer
- Sophisticated control concept for lowest possible energy and media consumption
- Multi-stage condensate filter at the cooling zone for efficient cleaning
- 15" touch-screen with user-friendly operator interface
- Process chamber made of stainless steel
- Modular cooling stage concept with 1 -5 cooling stages

All systems are available as air or nitrogen version and are suitable from small batch up to three shift operation.

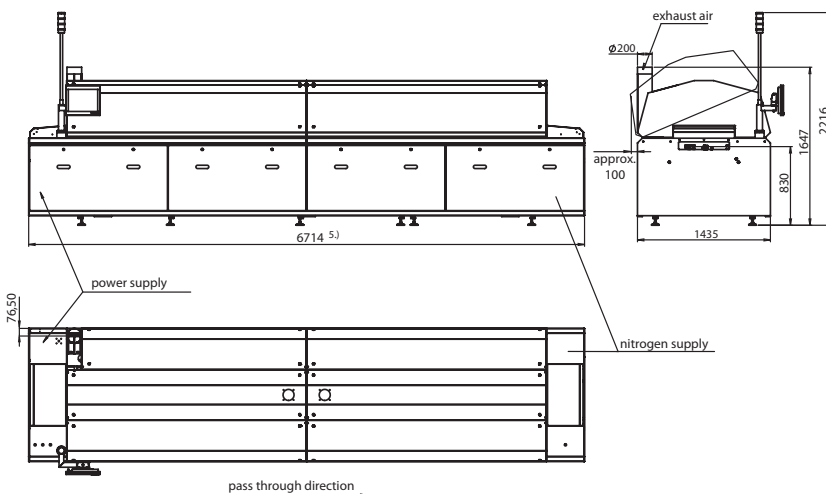

Technical Data SMT Quattro Peak® L Plus (N₂)

Overall dimensions	
Length (with 3-stage cooling zone): ^{5.)}	6714 mm
Width:	1435 mm
Height (in delivery condition / incl. warning light): ^{2.)}	1647 mm / 2216,5 mm
Inlet height, adjustable by customer: ^{2.)}	830 ... 1030 ±20 mm
Weight	
Number / diameter foot:	approx. 3000 kg
Max. floor loading:	12 / 80 mm
	750 kg/m ²
Process area	
Length:	5919 mm
Pre-heating zones:	5
Peak zone (top/bottom):	3 peak zones with 6 heating modules (3 top/3 bottom)
Bottom heating modules pre-heating zones (option):	5
Heated tunnel length, total:	4167 mm
Active convection length:	3629,5 mm
Length of cooling zone 1- / 2- / 3- / 4- / 5-stage:	1278,5 / 1752 / 2225,5 / 2822,5 / 3296 mm
Temperature measurement:	NiCr-Ni sensors in the hot gas flow
Warm-up time:	approx. 30 min.
Heat transfer:	100% forced convection
Process temperature (pre-heating zone/peak zone):	max. 300 °C (pre-heating zone) / 350 °C (Peak)
Transport chain conveyor	
Working width usable with PCB support:	60 ... 510 mm
Usable working width with PCB support:	PIN level ... -10 mm
Pass through height (top/bottom):	30/30 mm
Max. loading:	2 kg/m
Transport mesh belt conveyor	
Usable working width:	500 mm
Pass through height (top):	30 mm
Max. loading:	2 kg/m
Conveyor speed	
Average conveyor speed	0.2 ... 3.0 m/min.
	0.7 ... 1.2 m/min.
Exhaustion^{3.)}	
Suction pipe:	1 x Ø 200 mm
Required exhaust air at pipe (inlet):	approx. 600 ... 800 m ³ /h
Temperature of exhaust air at the pipe:	< 50 °C
Internal exhaust air resistance of oven:	3 - 8 mbar
Continuous sound pressure level	
	< 70 dB(A)
Control Unit	
	CDIAS with RT 7
Nitrogen supply * 4.)	
Connecting armature (clamped joint for Cu-pipe):	R 3/8" internal thread
Working pressure (at connecting armature):	6 ... 8 bar
N ₂ -consumption, steady state condition and transport width 220 mm: ^{6.)}	approx. 9 m ³ /h
N ₂ -consumption, full load and transport width 220 mm: ^{7.)}	approx. 15 m ³ /h
Readiness for the system (1000 ppm, N ₂ < 5 ppm O ₂):	approx. 15 min.
Power supply	
Connecting power supply:	3~N, PE 230 / 400 V, 50 Hz
Max. current consumption per phase:	95 A
Power consumption during heat-up:	64 kW
Power consumption steady state condition: ^{1.)}	approx. 9 kW h

1.) Machine with chain conveyor 220 mm transport width, fan regulation and no other options

2.) Standard height 830 mm; corresponding to a changed inlet height the other heights of the reflow system are changing

3.) Connection of a flexible, heat resisting (at least 100 °C) hose (available by SMT) or tube. The waste air exhausting unit width adjustable throttle valve mounted after the suction sleeves has to be installed by the user

4.) Nitrogen supply with filters for solid and liquid parts has to be mounted by the user, recommended supply of nitrogen with oxygen content < 5 ppm

5.) Corresponding to the numbers of cooling stages the length is changing

6.) 1000 ppm with option „intelligent nitrogen control“ and „sleeping mode“; if 500 ppm then approx. 10 m³/h

7.) With PCBs (220 x 220 mm), one PCB length distance, 1000 ppm; if 500 ppm then approx. 17 m³/h

* with option nitrogen only